

Variable air/gas ratio controls GIKH

TECHNICAL INFORMATION

- For maintaining a constant mixture of gas and air on systems using preheated air
- Design with inlet pressure compensation diaphragm ensures high control accuracy
- Adjustment of the gas flow to the air flow that varies due to the heating of the combustion air
- Variable air/gas ratio controls with differential pressure measuring unit for the control pressure
- High turndown
- EU certified

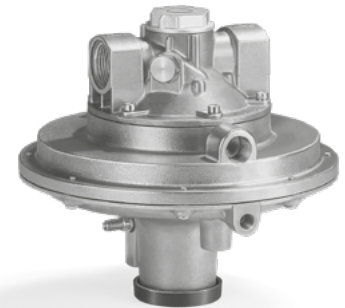

Contents

Contents	2
1 Application	3
1.1 Application examples	3
1.1.1 Continuous control	4
1.1.2 Continuous control for nominal sizes > DN 25	4
2 Certification	5
3 Function	6
4 Flow rate	7
4.1 Calculating the nominal size	7
4.2 Bypass screw flow rate	8
5 Selection	9
5.1 ProFi	9
5.2 Type code	9
6 Project planning information	10
6.1 Installation	10
7 Technical data	11
7.1 Dimensions	11
8 Converting units	12
9 Maintenance cycles	13
Fore more information	14

1 Application



The variable air/gas ratio control GIKH serves to maintain a constant gas/air pressure ratio and to control the gas pressure in systems using a recuperative air preheating system. When the burner capacity is changed and with varying combustion air temperature, the gas pressure is controlled such that the ratio (gas to cold air) remains constant.

For use in systems using preheated air in the iron, steel, glass and ceramics industries, as well as in commercial heat generation, such as the packaging, paper and food-stuffs industries.

1.1 Application examples



Bogie hearth furnace

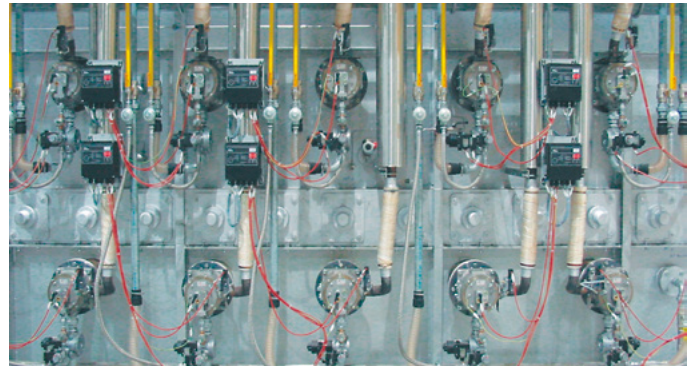

Roller hearth furnace



Intermittent shuttle kiln

1.1.1 Continuous control

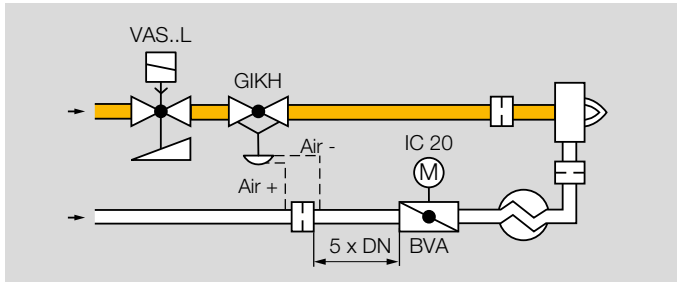

Continuous variable air/gas ratio control on one or multiple burners in hot-air operating mode. In multiple burner systems, the burners downstream of the measuring orifice may not be switched off individually. Safety valves which open slowly in the case of continuous control must always be installed upstream of the air/gas ratio control GIKH.

1.1.2 Continuous control for nominal sizes > DN 25

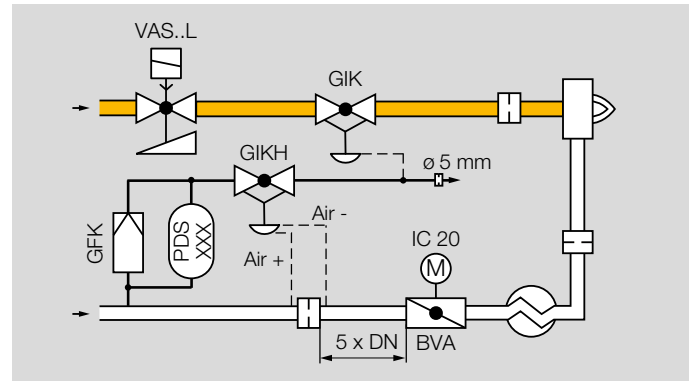

Continuous variable air/gas ratio control on one or multiple burners in hot air operating mode for gas pipes larger than DN 25. In multiple burner systems, the burners downstream of the measuring orifice may not be switched off individually. Safety valves must always be installed upstream of the variable air/gas ratio control GIKH. These safety valves must open slowly in the case of continuous control.

2 Certification

Certificates – see www.docuthek.com

EU certified



- (EU) 2016/426 (GAR) – Gas Appliances Regulation
- EN 88-1:2011+A1:2016

Eurasian Customs Union



The products GIKH meet the technical specifications of the Eurasian Customs Union.

3 Function

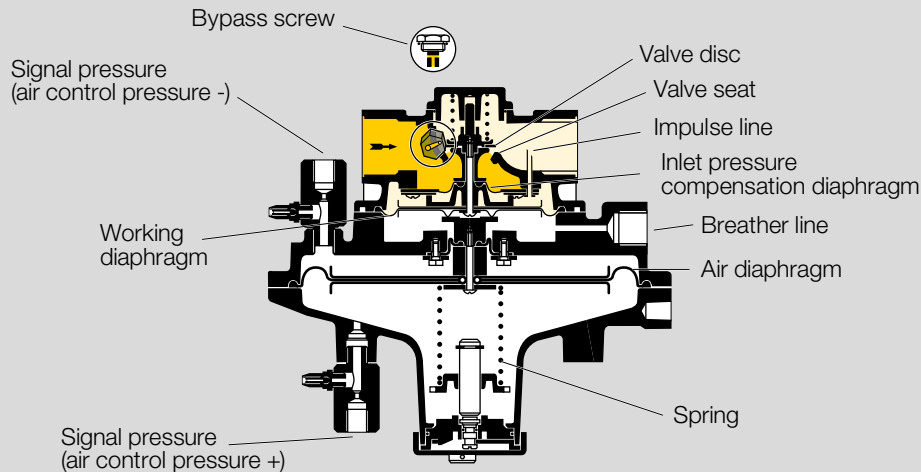

Variable air/gas ratio control GIKH is actuated by the differential pressure on the orifice in the air line. This pressure acts on the large air diaphragm. The valve plate is lifted from the valve seat and the gas flows into the regulator outlet area via the open valve seat. The outlet pressure is fed from the gas side to the space above the working diaphragm via the impulse line. The two pressure forces are compared and compensated. Thanks to the differing diaphragm diameters, the forces are balanced at a pressure ratio of 4:1. The inlet pressure compensation diaphragm ensures high control accuracy.

The spring can be used for compensating the weight of the measuring unit. In the low-fire rate range, the gas/air mixture can be set by adjusting the spring.

Adjustment at high-fire rate is carried out using orifices or valves on the burner.

The zero shut-off prevents an increase in the outlet pressure when the consumer is switched off.

A test nipple has been installed to measure the outlet pressure.

4 Flow rate

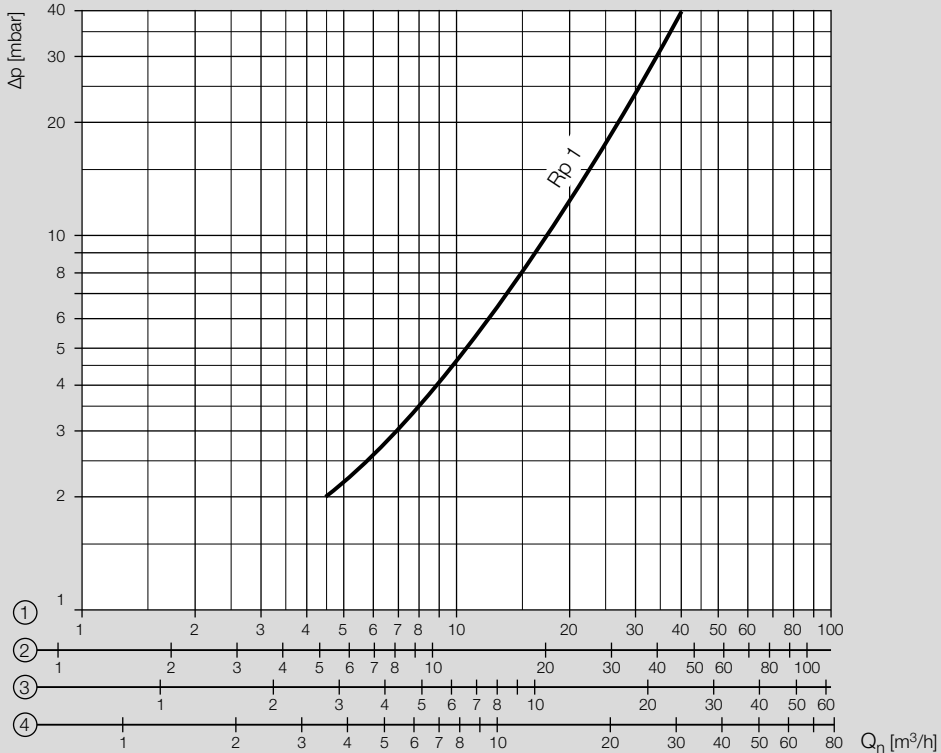

1 = natural gas ($\rho = 0.80 \text{ kg/m}^3$)

2 = town gas ($\rho = 0.58 \text{ kg/m}^3$)

3 = propane ($\rho = 2.01 \text{ kg/m}^3$)

4 = air ($\rho = 1.29 \text{ kg/m}^3$)

4.1 Calculating the nominal size

A web app selecting the correct product is available at www.adlatus.org.

4.2 Bypass screw flow rate

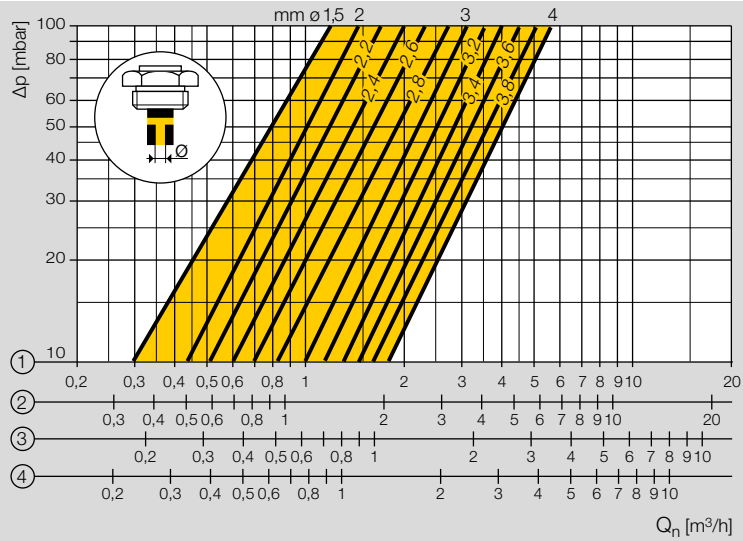

- 1 = natural gas ($\rho = 0.80 \text{ kg/m}^3$)
- 2 = town gas ($\rho = 0.58 \text{ kg/m}^3$)
- 3 = propane ($\rho = 2.01 \text{ kg/m}^3$)
- 4 = air ($\rho = 1.29 \text{ kg/m}^3$)

5 Selection

Variable air/gas ratio control GIKH is available in a single nominal size.

5.1 ProFi

A web app selecting the correct product is available at www.adlatus.org.

5.2 Type code

GIKH	Variable air/gas ratio control
25	Nominal size
R	Rp internal thread
02	p_U max. 200 mbar
-5	Pressure test point at the outlet
L	Only for air (without approval)
B	With bypass screw

6 Project planning information

An Rp ½ breather line must be connected when fitting into the gas line.

GIKH..B: the differential control pressure must be less than 0.5 mbar at low-fire rate.

6.1 Installation

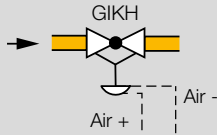

Installation position: install in horizontal pipelines only. The spring dome points downwards.

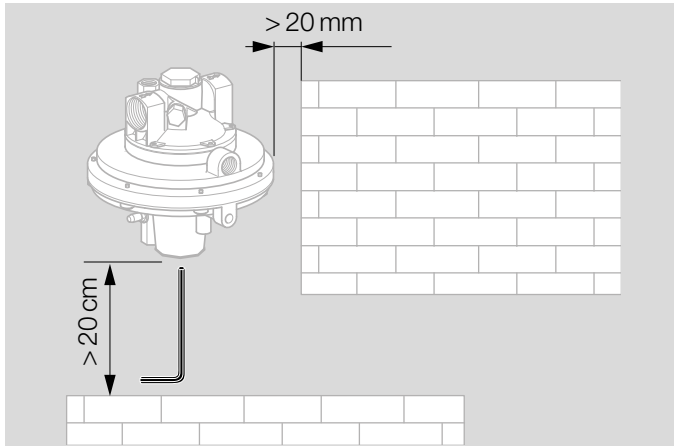

The variable air/gas ratio control GIKH must not be in contact with masonry. Ensure that there is sufficient space for adjusting the low-fire rate.

Do not store or install the unit in the open air.

Sealing material and dirt, e.g. thread cuttings, must not be allowed to get into the regulator housing. Install a filter (GFK) upstream of every system.

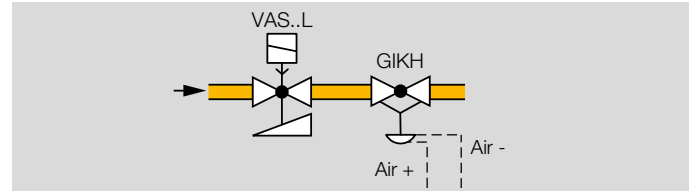

Safety valves VAS..L must always be installed upstream of the variable air/gas ratio control GIKH. These must be slow opening valves.

We recommend that a slowing down section of 3 x DN be provided downstream of the GIKH.

Every signal line whose failure may lead to the uncontrolled escape of gas and therefore to an unsafe status and gas fire must be made of metal.

7 Technical data

Gas types: natural gas, town gas, LPG (gaseous) and biogas (max. 0.02 %-by-vol. H₂S), GIKH..L also for air. The medium must be dry in all temperature conditions and must not contain condensate.

Inlet pressure p_U : max. 200 mbar.

Differential between inlet and outlet pressures:
max. 100 mbar.

Ambient temperature: -20 to +60°C.

No condensation permitted.

Long-term use in the upper ambient temperature range accelerates the ageing of the elastomer materials and reduces the service life (please contact manufacturer).

Storage temperature: -20 to +40°C.

Housing: aluminium.

Valve seat and stem: aluminium.

Valve plate: plastic.

Valve plate seal: NBR.

Diaphragms: NBR.

Bypass screw: brass.

When used for air: special version.

Internal thread: Rp to ISO 7-1.

Weight: 3.4 kg.

7.1 Dimensions

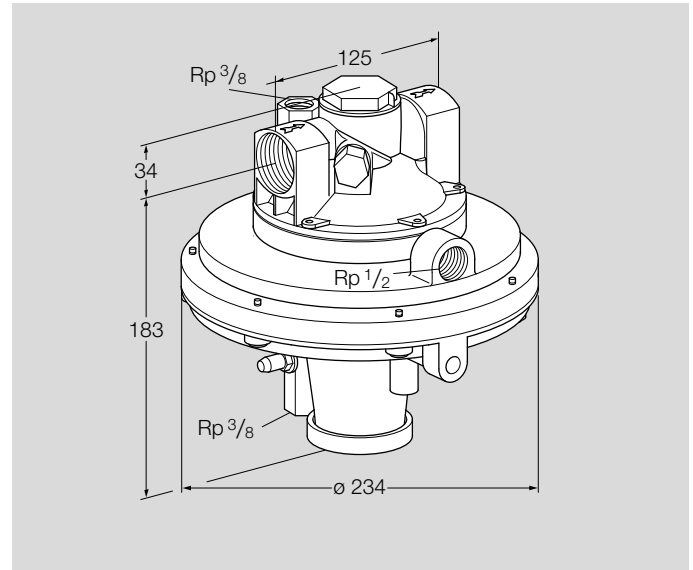

8 Converting units

See www.adlatus.org

9 Maintenance cycles

At least once a year, at least twice a year in the case of biologically produced methane.

Fore more information

The Honeywell Thermal Solutions family of products includes Honeywell Combustion Safety, Eclipse, Exothermics, Hauck, Kromschroder and Maxon. To learn more about our products, visit ThermalSolutions.honeywell.com or contact your Honeywell Sales Engineer.

Elster GmbH
Strotheweg 1, D-49504 Lotte
T +49 541 1214-0
hts.lotte@honeywell.com
www.kromschroeder.com

Global centralized service deployment coordination:
T +49 541 1214-365 or -555
hts.service.germany@honeywell.com

© 2019 Elster GmbH

We reserve the right to make technical modifications in the interests of progress.

Honeywell

**krom
schroder**