

Operating instructions

Safety shut-off valve JSAV 25–40



Contents

Safety shut-off valve JSAV 25–40	1
Contents	1
Safety	1
Checking the usage	2
Type code	2
Part designations	2
Type label	2
Installation	2
Connecting the impulse line	3
Tightness test	3
Checking the function	3
Checking the trip pressure	3
Checking the tightness of the valve disc	4
Setting the trip pressure	4
Replacing the spring	4
Resetting	5
Replacing the measuring unit	5
Replacing the valve disc	6
Maintenance	7
Technical data	7
Designed lifetime	7
Logistics	8
Certification	8
Declaration of conformity	8
Eurasian Customs Union	8
Contact	8

Safety

Please read and keep in a safe place



Please read through these instructions carefully before installing or operating. Following the installation, pass the instructions on to the operator. This unit must be installed and commissioned in accordance with the regulations and standards in force. These instructions can also be found at www.docuthek.com.

Explanation of symbols

■ **1, 2, 3...** = Action

> = Instruction

Liability

We will not be held liable for damage resulting from non-observance of the instructions and non-compliant use.

Safety instructions

Information that is relevant for safety is indicated in the instructions as follows:

⚠ DANGER

Indicates potentially fatal situations.

⚠ WARNING

Indicates possible danger to life and limb.

! CAUTION

Indicates possible material damage.

All interventions may only be carried out by qualified gas technicians. Electrical interventions may only be carried out by qualified electricians.

Conversion, spare parts

All technical changes are prohibited. Only use OEM spare parts.

Changes to edition 03.18

The following chapters have been changed:

- Technical data
- Logistics
- Certification

Checking the usage

JSAV

Safety shut-off valve for securing downstream fittings against excess gas pressure.

This function is only guaranteed when used within the specified limits—see page 7 (Technical data).

Any other use is considered as non-compliant.

Type code

Code	Description
JSAV	Safety shut-off valve
25–40	Nominal size
T	T-products range
R	Rp internal thread to ISO 7-1
N	NPT internal thread
F	PN 16 flange to ISO 7005
40	Max. inlet pressure p_U (PS) = 4 bar (58 psig)
/1	Over-pressure shut-off p_{do}
/2	Over-pressure and under-pressure shut-off p_{do}/p_{du}
-0	Without pressure test point
-3	Screw plug at the inlet and outlet

Part designations

JSAV 25

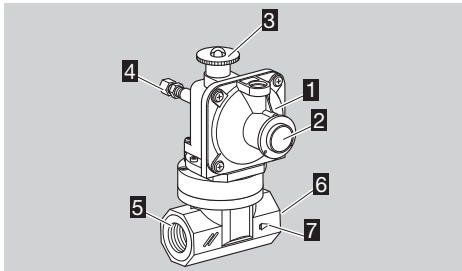

JSAV 40

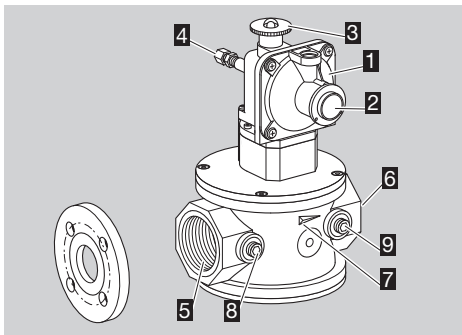

- 1** Measuring unit
- 2** Breather screw plug
- 3** Reset cap
- 4** Impulse line connection
- 5** Inlet
- 6** Outlet
- 7** Arrow of direction of flow
- 8** Inlet p_U (PS) measuring connection
- 9** Outlet p_d measuring connection

Type label

- ▷ Max. inlet pressure p_U (PS), upper trip pressure p_{do} and lower trip pressure p_{du} , ambient temperature T: see type label.

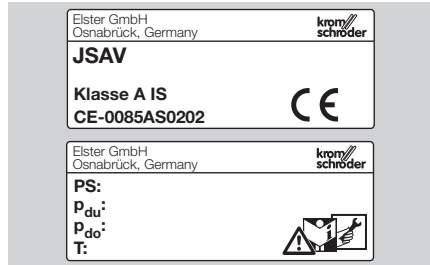

Installation

! CAUTION

Please observe the following to ensure that the JSAV is not damaged during installation:

- Sealing material, cuttings and other impurities must not be allowed to get into the housing.
 - We recommend installing a filter upstream of the JSAV in order to protect it against impurities in the pipe.
 - The installation location must be dry. Do not store or install the JSAV in the open air.
 - Dropping the device can cause permanent damage. In this event, replace the entire device and associated modules before use.
 - Install the JSAV in the pipe free of mechanical stress.
 - Do not clamp the unit in a vice or use it as a lever. On the JSAV..R, only secure the valve by holding the octagon at the inlet or outlet with a suitable spanner. Risk of external leakage.
 - Max. inlet pressure p_U (PS) 4 bar (58 psig).
- ▷ Installation in the vertical or horizontal position, never upside down.

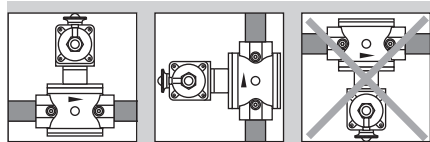

- 1** The housing must not be in contact with masonry. Minimum clearance 20 mm (0,78"). Ensure that there is sufficient space for installation and adjustment.
- 2** JSAV..R: seal pipe with approved sealing material.
- 3** Remove screw caps from the inlet and outlet on the JSAV.

- ▷ Note direction of flow.

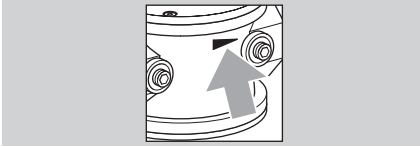

- ▷ We recommend installing a manual valve AKT 25 in the pipe leading to the safety relief valve VSBV 25, so that the annual function check of the safety shut-off valve JSAV can be carried out without having to remove it.
- ▷ To prevent the VSBV from being unintentionally shut off, we recommend removing the manual valve lever after commissioning and attaching it to the pipe.

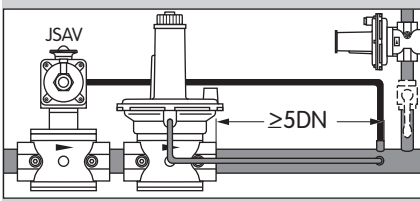

Connecting the impulse line

- ▷ The connection flange is suitable for an impulse line with a pipe diameter of 8 mm.

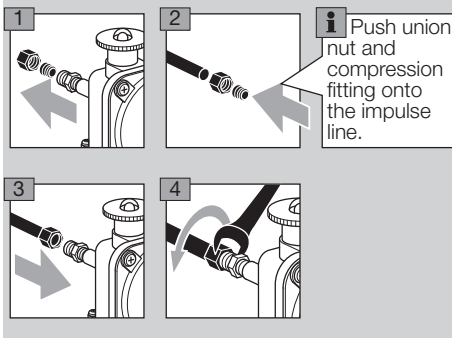

- ▷ On the JSAV..T, remove the blind plug and connect an 1/8" NPT impulse line.
- 5** Install the impulse line and seal with approved sealing material.
- ▷ Ensure that there is sufficient tube length for the impulse line.

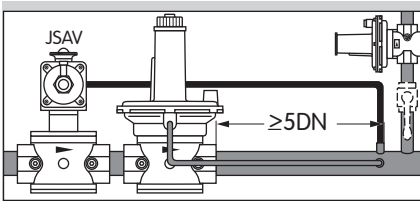

Tightness test

⚠ WARNING

- An additional tightness test must be carried out on the JSAV at all joints which have been opened for maintenance work or replacement of spare parts.
- ▷ Ensure that the valve seat of the JSAV is open, see page 5 (Resetting).
- 1** Block the pipeline at the inlet and outlet.
- ▷ Note max. test pressure. JSAV inlet and outlet: max. 6 bar (87 psig), impulse line: max. 750 mbar (10.9 psig).
- 2** Slowly apply test pressure.

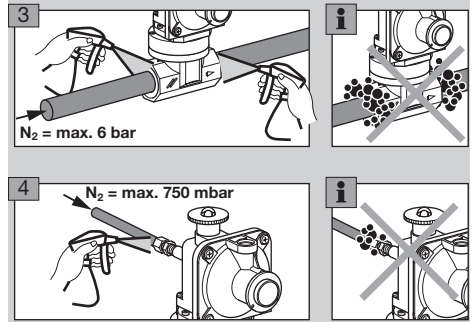

Checking the function

Checking the trip pressure

The JSAV is checked for the required trip pressure.

- 1** Vent the system.
- ▷ Ensure that the valve seat of the JSAV is open, see page 5 (Resetting).
- ▷ Ensure that the breather screw plug is screwed in.
- 2** Close all manual valves at the inlet and outlet, and in the relief line.

! CAUTION

Please observe the following to ensure that the regulator is not damaged during the function check:

- Do not exceed the maximum outlet pressure p_d of the regulator.
- 3** Lower or increase the outlet pressure p_d on the regulator until the required trip pressure p_{do} or p_{du} is reached.

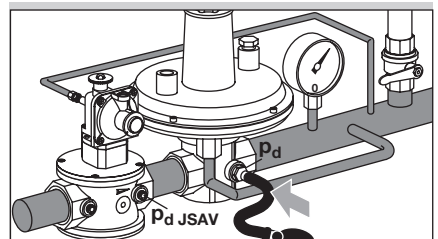

- ▷ The JSAV closes at the set trip pressure.

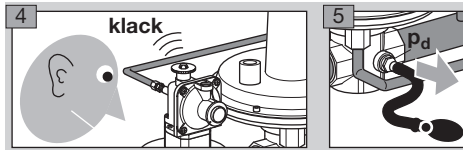

- ▷ The JSAV has closed successfully: to restart the system, the JSAV must be opened again, see page 5 (Resetting).
- ▷ The JSAV does not close at the required trip pressure and must be readjusted, see page 4 (Setting the trip pressure).

Checking the tightness of the valve disc

- ▷ Ensure that the outlet is closed.
- 1** Vent the system.
- 2** Slowly open the manual valve at the inlet.
- 3** The outlet pressure $p_{d\text{JSAV}}$ must not rise.

Setting the trip pressure

- 1** Select the upper trip pressure p_{do} according to the outlet pressure p_d of the pressure regulator.

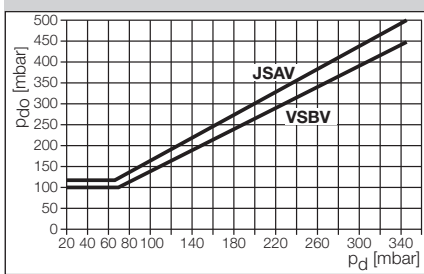

- 2** Remove the breather screw plug.
- 3** Adjust the selected upper trip pressure p_{do} and the lower trip pressure p_{du} . Determine p_{du} depending on the system conditions.

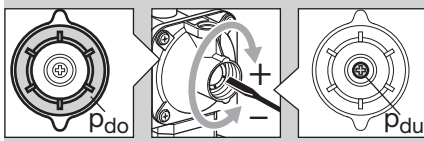

- 4** Reset the JSAV, see page 5 (Resetting).
- 5** Check the upper and lower trip pressure again, see page 3 (Checking the function).

Replacing the spring

- ▷ Various trip pressure ranges can be achieved by using different springs on the JSAV.
- 1** Choose a spring/springs according to the required trip pressure.

Spring table

Upper trip pressure p_{do} [mbar]	["WC]	Marking	Order No.
18–60*	7–23.4*	black	03089068*
50–80	19.5–31.2	orange	03089069
60–110	23.4–42.9	red	03089070
100–210**	39–81.9**	dark green	03089071**
200–350	78–136.5	yellow	03089072
280–500	109.2–195	white	03089073

Lower trip pressure p_{du} [mbar]	["WC]	Marking	Order No.
8–16**	3.12–6.24**	light blue	03089082**
16–60	6.24–23.4	brown	03089083
60–150	23.4–58.5	violet	03089084

* Approved for pressures from 40 mbar and higher

** Standard spring

Removing the spring(s)

- 1** Depressurize the system.
- ▷ To be able to change the springs, we recommend dismantling the measuring unit of the JSAV, see page 5 (Replacing the measuring unit).
- 2** Once the measuring unit has been dismantled, remove the listed individual parts from the measuring unit one after the other.
- ▷ Attention! The individual parts are compressed.

Part designations

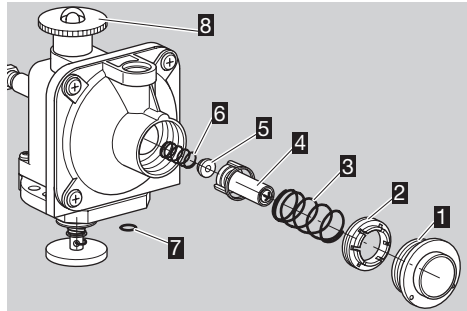

- 1** Breather screw plug
- 2** Counter bearing for spring p_{do}
- 3** Spring p_{do}
- 4** Spring seat
- 5** Counter bearing for spring p_{du}
- 6** Spring p_{du}
- 7** O-ring
- 8** Reset cap

Inserting new spring(s)

- 3** Carefully clamp the measuring unit in the horizontal position in a vice to ensure simple assembly of the individual parts. The dome into which the breather screw plug is screwed should be pointing upwards.
- 4** Re-insert and assemble the individual parts in the dome in reverse order using tweezers or small pincers.

- ▷ Caution when inserting the counter bearing **5**! The smaller diameter must be inside the spring p_{du} .
- ▷ The bars on the spring seat **4** must be positioned in the grooves of the dome.
- ▷ Do not fit the breather screw plug yet.
- 5** Fit the measuring unit. Ensure that the O-ring **7** has been re-inserted.
- 6** Connect the impulse line to the JSAV.
- 7** Adjust the required trip pressures, see page 4 (Setting the trip pressure).
- 8** After inserting the springs, take the springs' adhesive labels from the packaging and stick them below the type label on the JSAV.
- 9** Clearly mark the adjusted trip pressures p_{do} and p_{du} on the adhesive label(s).
- 10** Fit the breather screw plug.
- 11** Check tightness and function, see page 3 (Tightness test) and page 3 (Checking the function).

Resetting

- ▷ Ensure that the pressure of the impulse line is between the upper and lower trip pressure.
- 1** Remove the breather screw plug.
- 2** Turn the reset cap and pull it approx. 1 to 2 mm (0.04 to 0.08") upwards. Pressure equalization between inlet and outlet now takes place.

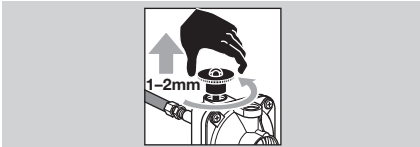

- 3** Hold the reset cap in this position until the cap can be pulled further upwards easily following pressure equalization.
- 4** Pull the reset cap upwards until the valve disc clicks into place. The JSAV is now fully open.

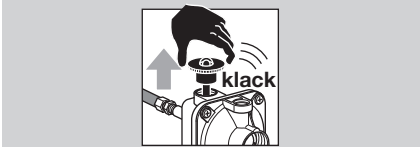

- 5** Fit the reset cap again.
- ▷ Once the cap has been screwed on, the green dot in the reset cap must be right at the top.

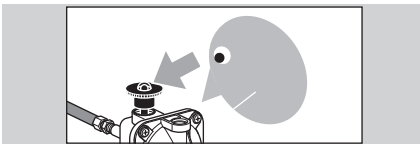

- 6** Fit the breather screw plug.
- ▷ The JSAV is ready for operation.

Replacing the measuring unit

- ▷ The measuring unit has to be replaced if the JSAV no longer opens or can no longer be reset.
- ▷ We recommend cleaning the O-ring seats and lightly greasing the O-rings with Klüber Nontrop ZB91 DIN before installation.
- 1** Depressurize the system.

JSAV 25

- ▷ The measuring unit is supplied with the valve disc assembled. 1 O-ring and 4 screws are enclosed.
- 2** Detach the impulse line from the JSAV.

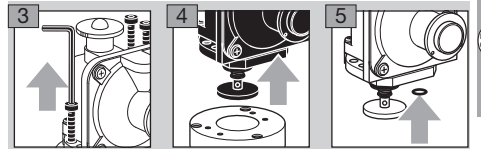

- ▷ Ensure that the O-ring is fitted in the new measuring unit, see Figure **5**.
- 6** Follow the reverse procedure when reassembling.
- 7** Connect the impulse line to the JSAV.
- 8** Check tightness and function, see page 3 (Tightness test) and page 3 (Checking the function).

JSAV 40

- ▷ The measuring unit is supplied with the valve disc assembled. 1 O-ring and 4 screws are enclosed.
- 2** Detach the impulse line from the JSAV.

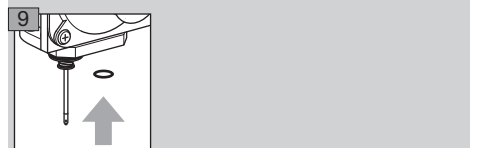
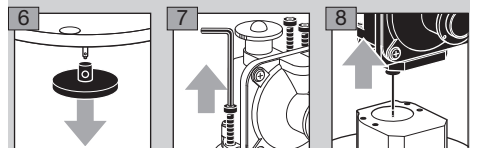
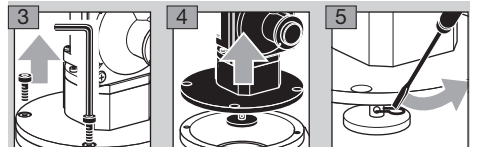

- ▷ Ensure that the O-ring is fitted in the new measuring unit, see Figure **9**.
- 10** Replace the O-ring on the housing. The O-ring is part of the seal set.

- ▷ The seal set is available separately as a spare part.

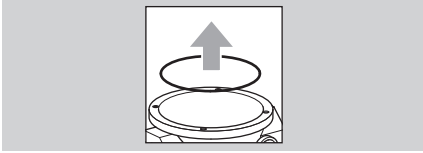

- 11** Follow the reverse procedure when reassembling.
- 12** Connect the impulse line to the JSAV.
- 13** Check tightness and function, see page 3 (Tightness test) and page 3 (Checking the function).

Replacing the valve disc

- ▷ The valve disc has to be replaced if the JSAV is leaking.
- ▷ We recommend cleaning the O-ring seats and lightly greasing the O-rings with Klüber Nontrop ZB91 DIN before installation.

- 1** Depressurize the system.

JSAV 25

- ▷ The valve disc is supplied with a complete seal set. We recommend replacing all seals.

- 2** Detach the impulse line from the JSAV.

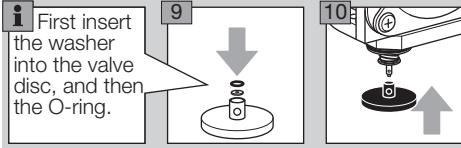
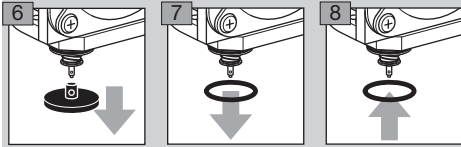
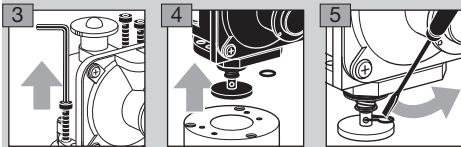

- i** First insert the washer into the valve disc, and then the O-ring.

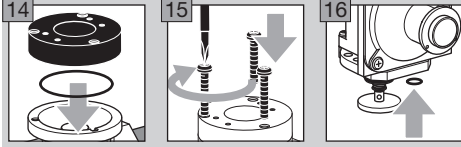
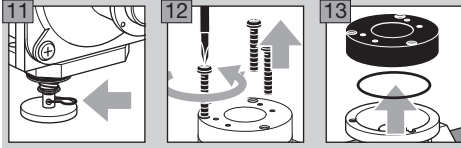

- ▷ Ensure that the O-ring is fitted in the new measuring unit, see Figure 16.

- 17** Follow the reverse procedure when reassembling.

- 18** Connect the impulse line to the JSAV.

- 19** Check tightness and function, see page 3 (Tightness test) and page 3 (Checking the function).

JSAV 40

- ▷ The valve disc is supplied with a complete seal set. We recommend replacing all seals.

- 2** Detach the impulse line from the JSAV.

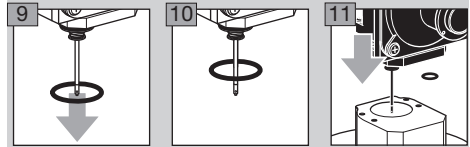
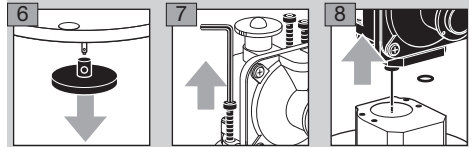
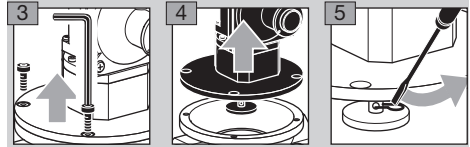

- ▷ Ensure that the O-ring is fitted in the new measuring unit, see Figure 11.

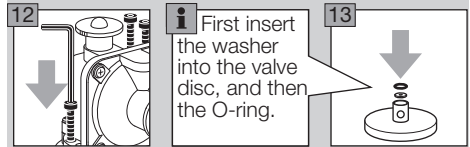

- i** First insert the washer into the valve disc, and then the O-ring.

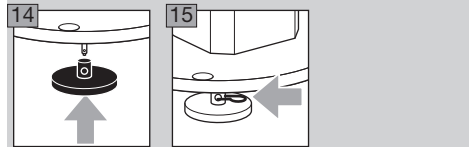

- ▷ Replace the O-rings on the housing and the valve seat.

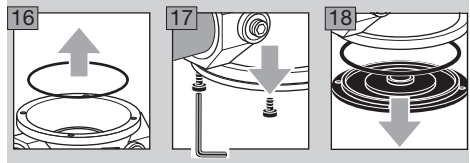

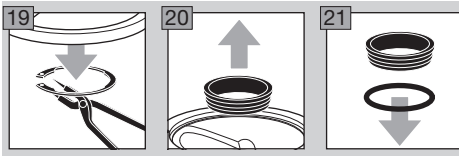

- 22** Follow the reverse procedure when reassembling using the O-rings from the seal set.
- 23** We also recommend replacing the sealing rings on the pressure test points.
- 24** Connect the impulse line.
- 25** Check tightness and function, see page 3 (Tightness test) and page 3 (Checking the function).

Maintenance

In order to ensure smooth operation:
Check the function and tightness of the JSAV every year, or every six months if operated with biologically produced methane, see page 3 (Checking the function) and page 3 (Tightness test).

- ▷ In the case of malfunctioning, check the measuring unit and valve disc and replace if necessary.
Selecting spare parts:
see www.adlatus.org, PartDetective.
Replacing spare parts:
see page 5 (Replacing the measuring unit),
see page 6 (Replacing the valve disc).
- ▷ After carrying out maintenance work or replacing spare parts, check for tightness and function, see page 3 (Tightness test) and page 3 (Checking the function).

Technical data

Ambient conditions

Icing, condensation and dew in and on the unit are not permitted.

Avoid direct sunlight or radiation from red-hot surfaces on the unit.

Note the maximum medium and ambient temperatures!

Avoid corrosive influences, e.g. salty ambient air or SO₂.

The unit may only be stored/installed in enclosed rooms/buildings.

Ambient temperature:

-15 to +60°C (5 to 140°F).

Long-term use in the upper ambient temperature range accelerates the ageing of the elastomer materials and reduces the service life (please contact manufacturer).

Transport temperature: -15 to +60°C (5 to 140°F).

Storage temperature: -15 to +40°C (5 to 104°F).

This unit is not suitable for cleaning with a high-pressure cleaner and/or cleaning products.

Mechanical data

Gas type: natural gas, town gas, LPG (gaseous), biogas (max. 0.02 %-by-vol. H₂S) = Group 1 fluids pursuant to Directive 2014/68/EU or air.

Medium temperature = ambient temperature.

The gas must be dry in all temperature conditions and must not contain condensate.

Max. inlet pressure p₀ (PS) 4 bar (58 psig).

Max. test pressure for testing the JSAV:

temporarily < 15 min. 6 bar (87 psig).

Max. test pressure for testing the impulse line:

temporarily < 15 min. 750 mbar (10.8 psig).

Trip pressures pre-set at the factory to:

p_{do}: 120 mbar (46.8 "WC),

p_{du}: 10 mbar (3.9 "WC).

Trip pressure ranges, see page 4 (Replacing the spring), Spring table.

Accuracy group: AG 10.

Connection for housing:

JSAV..R: Rp internal thread to ISO 7-1,

JSAV..N: NPT internal thread,

JSAV..F: PN 16 flange to ISO 7005.

Connection for impulse line:

DN 8 (1/8" NPT).

Housing: AISi,

diaphragm: NBR,

valve seat: aluminium,

valve stem: stainless steel,

valve disc: steel with vulcanized NBR seal.

Designed lifetime

This information on the designed lifetime is based on using the product in accordance with these operating instructions. Once the designed lifetime has been reached, safety-relevant products must be replaced.

Designed lifetime (based on date of manufacture) in accordance with DIN EN 14382 Safety devices for gas pressure regulating stations and installations: 10 years.

You can find further explanations in the applicable rules and regulations and on the afecor website (www.afecor.org).

This procedure applies to heating systems. For thermoprocessing equipment, observe local regulations.

Logistics

Transport

Protect the unit from external forces (blows, shocks, vibration).

Transport temperature: see Technical data.

Transport is subject to the ambient conditions described.

Report any transport damage on the unit or packaging without delay.

Check that the delivery is complete, see page 2 (Part designations).

Storage

Storage temperature: see Technical data.

Storage is subject to the ambient conditions described.

Storage time: 6 months before using for the first time. If stored for longer than this, the overall service life will be reduced by the corresponding amount of extra storage time.

Packaging

The packaging material is to be disposed of in accordance with local regulations.

Disposal

Components are to be disposed of separately in accordance with local regulations.

Certification

Declaration of conformity



We, the manufacturer, hereby declare that the product JSAV 25 – 40 with product ID No. CE-0085AS0202 complies with the requirements of the listed Directives and Standards.

Directives:

- Pressure Equipment Directive (2014/68/EU), Class A
JSAV 25 – 40 with over-pressure/under-pressure shut-off
- Pressure Equipment Directive (2014/68/EU), Class B
JSAV 25 – 40 with over-pressure shut-off

Regulation:

- (EU) 2016/426 – GAR

Standards:

- DIN EN 14382:2009

The relevant product corresponds to the tested type sample.

The production is subject to the surveillance procedure pursuant to Regulation (EU) 2016/426 Annex III paragraph 3 and to Directive 2014/68/EU Annex III Module D1.

Elster GmbH

Scan of the Declaration of conformity (D, GB), see www.docuthek.com.

Eurasian Customs Union



The product JSAV meets the technical specifications of the Eurasian Customs Union.

Contact

If you have any technical questions, please contact your local branch office/agent. The addresses are available on the Internet or from Elster GmbH.

We reserve the right to make technical modifications in the interests of progress.

Honeywell

**krom//
schroder**

Elster GmbH
Strotheweg 1, D-49504 Lotte (Büren)

Tel. +49 541 1214-0

Fax +49 541 1214-370

hts.lotte@honeywell.com, www.kromschroeder.com