

Operating instructions
Linear flow control VFC
Linear flow control with actuator IFC

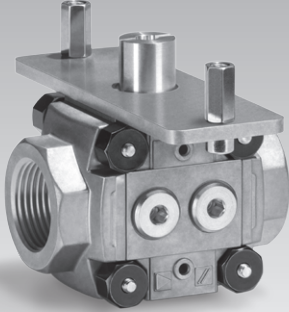

Contents

Linear flow control VFC 1
Linear flow control with actuator IFC 1
Contents 1
Safety 1
Checking the usage 2
 Type code 2
 VFC part designations 2
 IFC part designations 3
 IC 30 part designations 3
Installation 3
Wiring 4
Tightness test 4
Setting the flow rate 4
Accessories 5
 Fastening set IC-BVG../VFC 5
 Adapter set IC 30/VFC 5
 Seal set for sizes 1 and 3 5
Maintenance 5
Technical data 5
Logistics 6
Certification 6
 Declaration of conformity 6
 Eurasian Customs Union 6
Contact 6

Safety

Please read and keep in a safe place



Please read through these instructions carefully before installing or operating. Following the installation, pass the instructions on to the operator. This unit must be installed and commissioned in accordance with the regulations and standards in force. These instructions can also be found at www.docuthek.com.

Explanation of symbols

■, **1**, **2**, **3**... = Action
 > = Instruction

Liability

We will not be held liable for damage resulting from non-observance of the instructions and non-compliant use.

Safety instructions

Information that is relevant for safety is indicated in the instructions as follows:

⚠ DANGER

Indicates potentially fatal situations.

⚠ WARNING

Indicates possible danger to life and limb.

! CAUTION

Indicates possible material damage.

All interventions may only be carried out by qualified gas technicians. Electrical interventions may only be carried out by qualified electricians.

Conversion, spare parts

All technical changes are prohibited. Only use OEM spare parts.

Changes to edition 01.16

The following chapters have been changed:

- Installation
- Accessories
- Technical data

Checking the usage

VFC

The linear flow control is designed to adjust volumes of gas and cold air on various appliances. The VFC with actuator IC 20/IC 30/IC 40 (IFC) is suitable for regulating flow rates for control ratios up to 25:1 in modulating-controlled or stage-controlled combustion processes.

Linear flow control VFC and actuator IC 20 or IC 40 can be supplied separately or assembled. IC 30 is supplied separately.

This function is only guaranteed when used within the specified limits – see also page 5 (Technical data). Any other use is considered as non-compliant.

Type code

Code	Description
VFC	Linear flow control
IFC	Linear flow control with actuator
1	Size 1
3	Size 3
T	T-product
10	Inlet flange: DN 10 (3/8")
15	DN 15 (1/2")
20	DN 20 (3/4")
25	DN 25 (1")
40	DN 40 (1 1/2")
50	DN 50 (2")
65	DN 65 (2 1/2")
-	no inlet flange
/10	Outlet flange: DN 10 (3/8")
/15	DN 15 (1/2")
/20	DN 20 (3/4")
/25	DN 25 (1")
/40	DN 40 (1 1/2")
/50	DN 50 (2")
/65	DN 65 (2 1/2")
/-	no outlet flange
R	Rp internal thread
N	NPT internal thread
F	ISO flange
05	$p_{U \text{ max.}}$ 500 mbar
-08	
-15	
-20	
-25	
-32	
-40	Cylinder size

Accessories, right, inlet

P	Plug
M	Pressure test point
1	Gas pressure switch DG 17VC
2	Gas pressure switch DG 40VC
3	Gas pressure switch DG 110VC
4	Gas pressure switch DG 300VC
-	No accessories

Code	Description
Accessories, right, outlet	
P	Plug
M	Pressure test point
-1	Gas pressure switch DG 17VC
-2	Gas pressure switch DG 40VC
-3	Gas pressure switch DG 110VC
-4	Gas pressure switch DG 300VC
-	No accessories
The same accessories can be selected for the left- or right-hand side.	
/20	Actuator IC 20
/40	Actuator IC 40
Running time [s]/90°:	
-07	7.5
-15	15
-30	30
-60	60
Mains voltage:	
W	230 V AC, 50/60 Hz
Q	120 V AC, 50/60 Hz
A	100 – 230 V AC, 50/60 Hz
Torque:	
2	2.5 Nm
3	3 Nm
T	Three-point step control
E	0 (4) – 20 mA, 0 – 10 V continuous control
D	Digital input
A	4 – 20 mA analogue input
R10	1000 Ohm feedback potentiometer
Mounting actuator with electrical connection:	
no specification	outlet side
-I	inlet side

VFC part designations

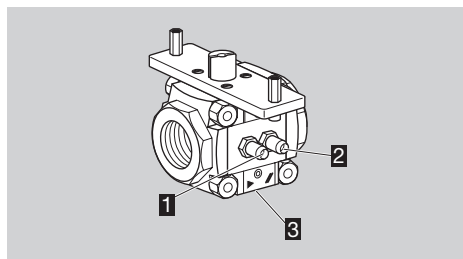

- 1** Test point for inlet pressure p_U
- 2** Test point for outlet pressure p_D
- 3** Adjusting spindle

IFC part designations

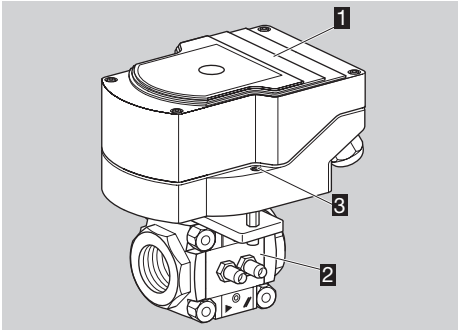

- 1 Actuator IC 20/40
- 2 Linear flow control VFC
- 3 Fastening set IC 20/40

IC 30 part designations

Actuator IC 30 is only supplied separately to linear flow control VFC.

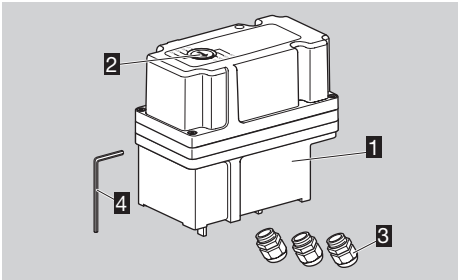

- 1 Actuator IC 30
- 2 Position indicator
- 3 3 x M16 plastic cable glands (enclosed)
- 4 Allen key (enclosed)

VFC type label

- ▷ Inlet pressure p_u , differential pressure dp and ambient temperature – see type label.

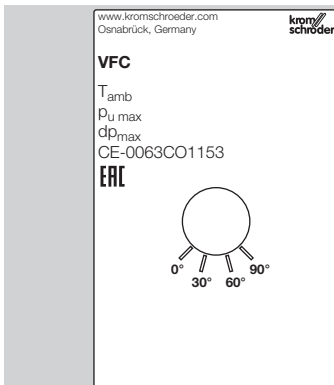

Installation

! CAUTION

Please observe the following to ensure that the VFC is not damaged during installation:

- Sealing material, thread cuttings and other impurities must not be allowed to get into the housing. Install a filter or dirt trap upstream of every control.
- Do not store or install the unit in the open air.
- Use approved sealing material only.
- Install the VFC in the pipe free of mechanical stress.
- Avoid subjecting the unit to strong impact/shocks.
- Do not clamp the unit in a vice or use it as a lever. Only secure the flange by holding the octagon with a suitable spanner. Risk of external leakage.
- Max. inlet pressure $p_{u \max}$. 500 mbar.
- Installation position for VFC with IC 30: as required.
- Installation position for IFC../20 and IFC../40: vertical or horizontal, never upside down.

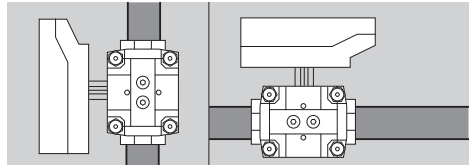

- ▷ The VFC and IC can be assembled before or after the VFC has been installed in the pipework.
- ▷ The fastening set for the assembly of VFC and IC is delivered separately – see page 5 (Accessories).
- ▷ The IC may be installed rotated by 180°. Note the direction of rotation of the actuator.
- ▷ The mounted actuator IC must not be rotated.
- ▷ Actuator IC is supplied in the closed position (0°) and linear flow control VFC in the open position (90°).

- 1 In order to mount the actuator, turn the VFC to the closed position (0°) manually.

Mounting IC 20 or IC 40

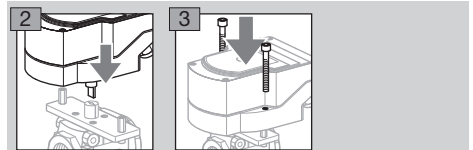

Mounting IC 30

- ▷ For the assembly of VFC and IC 30, an adapter set can be supplied as an accessory, see page 5 (Accessories).
- ▷ In order to mount the IC 30 to the VFC, the spacers must be replaced.

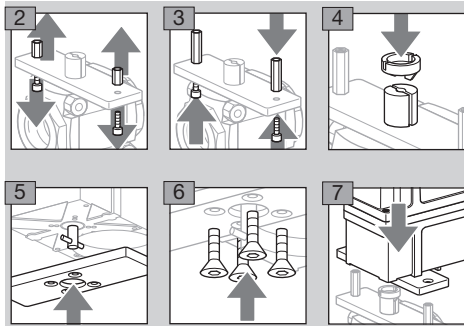

- ▷ The cylinder pin in the drive shaft must be locked in the coupling.

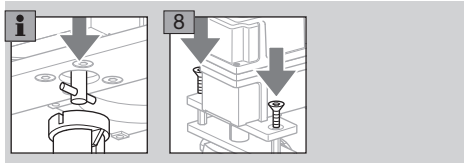

Installing the VFC with flanges in the pipe

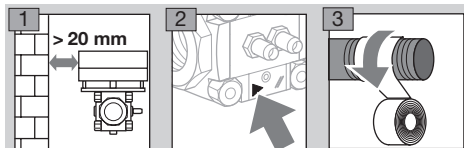

Installing the VFC without flanges in the pipe

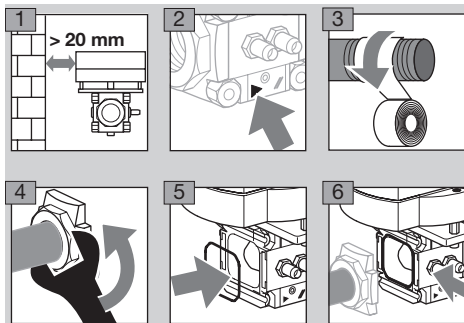

Wiring

Electrical connection of the IC, see enclosed Actuator IC 20/IC 30/IC 40 operating instructions or go to www.docuthek.com.

Tightness test

- ▷ Shut off the gas supply.
- 1 Close off the outlet of the VFC with a blanking plate or close the solenoid valve for gas downstream of the VFC.

The VFC is in the closed position once the IC has been installed:

- 2 Set the IC 20, IC 30 in Manual mode, or the IC 40 using BCSofT, to 100% open position, see enclosed Actuator IC 20/IC 30/IC 40 operating instructions or go to www.docuthek.com.

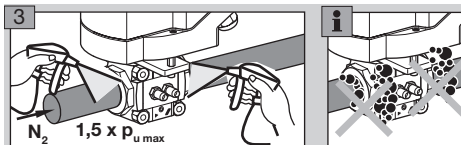

- 4 Tightness OK: remove the blanking plate or open the solenoid valve for gas downstream of the VFC.
- 5 Once the tightness test has been carried out successfully, move the VFC to the closed position once more using the actuator IC.
- ▷ Pipeline leaking: replace O-ring on flange, see page 5 (Seal set for sizes 1 and 3). Then check for tightness once again.
- ▷ Unit leaking: remove the unit and return it to the manufacturer.

Setting the flow rate

! CAUTION

When setting a higher flow rate, do not turn the adjusting spindle further than the stop (= maximum flow rate). It must not be unscrewed completely. The VFC is set to the maximum flow rate at the factory.

- ▷ Check the VFC for tightness after each adjustment of the adjusting spindle, see page 4 (Tightness test).
- ▷ The flow rate can be adjusted using the adjusting spindle (2.5 Allen key) in the base plate: turning it clockwise will reduce the flow rate, turning it anti-clockwise will increase the flow rate.

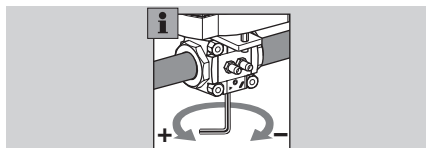

- ▷ The VFC is controlled by the IC, see enclosed Actuator IC 20/IC 30/IC 40 operating instructions or go to www.docuthek.com.

Accessories

Fastening set IC-BVG../VFC

For the assembly of VFC and IC 20 or IC 40. The fastening set is fitted at the factory or delivered enclosed as an additional item.

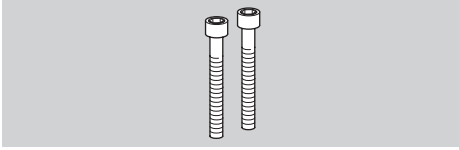

Order No.: 74921082

Adapter set IC 30/VFC

For the assembly of VFC and IC 30. The adapter set is delivered enclosed as an additional item.

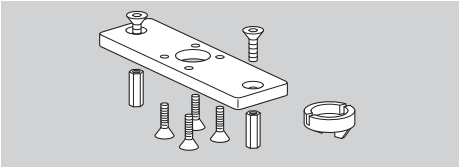

Order No.: 74340194

Assembly, see Installation, page 4 (Mounting IC 30).

Seal set for sizes 1 and 3

- ▷ When retrofitting accessories or a second valVario control or when servicing, we recommend replacing the seals.

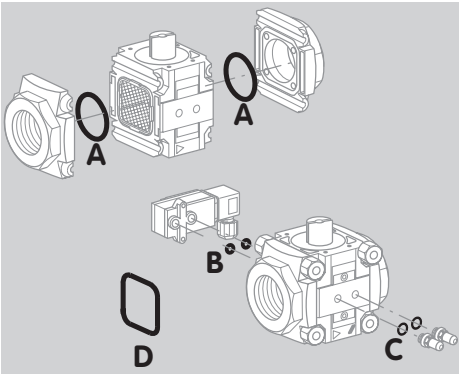

- ▷ Order No. for size 1: 74921988, size 3: 74921990.
- ▷ Scope of delivery:
 - A** 2 x O-rings (flange),
 - B** 2 x O-rings (pressure switch), for test point/screw plug:
 - C** 2 x sealing rings (flat sealing), 2 x profiled sealing rings,
 - D** 1 x double block seal; this is not required for VFC.

Maintenance

In order to ensure smooth operation, check the tightness and function of the VFC every year, or every six months if operated with biogas.

- ▷ After carrying out the maintenance work, check for tightness, see page 4 (Tightness test).
- ▷ The VFC suffers little wear and requires little servicing.

Technical data

Gas type: natural gas, LPG (gaseous), biogas (max. 0.1 %-by-vol. H₂S) or clean air; other types of gas on request. The gas must be dry in all temperature conditions and must not contain condensate.

Control ratio: 25:1.

Leakage rate: < 2% of k_{V5} value.

Max. inlet pressure p_{u max.}: 500 mbar (7.25 psi).

Running times:

IC 20: 7.5 s, 15 s, 30 s, 60 s

IC 30: 30 s, 60 s

IC 40: 4.5 s – 76.5 s.

Connection flanges: Rp internal thread pursuant to ISO 7-1.

Housing material: aluminium,

control cylinder: aluminium,

flow restricting cylinder: POM/aluminium,

seal: HNBR/NBR.

Ambient temperature: -20 to +60°C (-4 to +140°F).

Long-term use in the upper ambient temperature range accelerates the ageing of the elastomer materials and reduces the service life (please contact manufacturer).

Storage temperature: -20 to +40°C (-4 to +104°F).

Logistics

Transport

Protect the unit from external forces (blows, shocks, vibration). On receipt of the product, check that the delivery is complete, see page 2 (VFC part designations). Report any transport damage immediately.

Storage

Store the product in a dry and clean place.
Storage temperature: see page 5 (Technical data).
Storage time: 6 months in the original packaging before using for the first time. If stored for longer than this, the overall service life will be reduced by the corresponding amount of extra storage time.

Packaging

The packaging material is to be disposed of in accordance with local regulations.

Disposal

Components are to be disposed of separately in accordance with local regulations.

Certification

Declaration of conformity

We, the manufacturer, hereby declare that the product VFC, marked with product ID No. CE-0063CO1153, complies with the essential requirements of the following Directives and Standards:

Directives:

- 2009/142/EC – GAD (valid until 20 April 2018)

Regulation:

- (EU) 2016/426 – GAR (valid from 21 April 2018)

Standards:

- EN 13611

The relevant product corresponds to the type tested by the notified body 0063.

The production is subject to the surveillance procedure pursuant to Directive 2009/142/EC Annex II paragraph 3 (valid until 20 April 2018) and to Regulation (EU) 2016/426 Annex III paragraph 3 (valid from 21 April 2018).

Elster GmbH

Scan of the Declaration of conformity (D, GB) – see www.docuthek.com

Eurasian Customs Union



The product VFC meets the technical specifications of the Eurasian Customs Union.

Contact

If you have any technical questions, please contact your local branch office/agent. The addresses are available on the Internet or from Elster GmbH.

We reserve the right to make technical modifications in the interests of progress.

Honeywell

**krom//
schroder**

Elster GmbH
Strotheweg 1, D-49504 Lotte (Büren)

Tel. +49 541 1214-0

Fax +49 541 1214-370

hts.lotte@honeywell.com, www.kromschroeder.com